

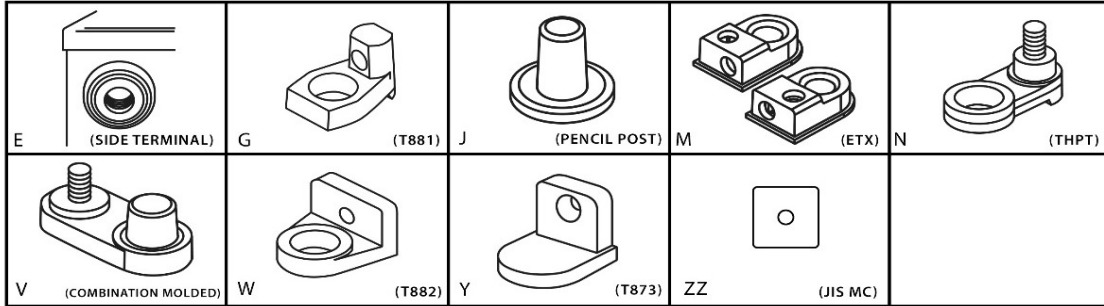

Special Order Batteries

Effective January 2, 2024
Supersedes all previous information
Subject to change without notice

GROUP NO.	ITEM NUMBER	PART NO.	PERFORMANCE LEVEL			WEIGHT (lbs)	MAXIMUM OVERALL DIMENSIONS						WARRANTY FREE MO.	FOOTNOTES		
			CCA	R.C.	REF. CA		LENGTH		WIDTH		HEIGHT					
							in	mm	in	mm	in	mm				
12-VOLT AUTOMOTIVE																
41 (T65)	980061275	641MF	650	100	800	38	11-9/16	293	6-7/8	175	6-7/8	175	36	22		
42 (T5/LB2)	980061530	642MF	475	70	585	29	9-9/16	242	6-7/8	175	6-7/8	175	36	—		
67R	980061531	667RMF	390	65	480	25	8-1/4	210	6-7/8	175	6-7/8	175	36	17,22		
79	980061552	779MF	840	140	1035	43	12-1/16	307	7-1/16	179	7-3/8	188	36	22,E		
85	980061532	685MF	650	110	800	34	9	229	6-7/8	175	8-1/8	206	36	22		
91 (T6/LB3)	980061533	691MF	700	100	860	37	11	278	6-7/8	175	6-7/8	175	36	17,22		
92 (T7/LB4)	980061534	692MF	650	130	800	43	12-1/2	317	6-7/8	175	6-7/8	175	36	17,22		
93 (T8/LB5)	980061537	693MF	800	130	985	46	13-15/16	354	6-7/8	175	6-7/8	175	36	17,22		
95R (H9/L6)	980061542	695RMF	850	190	1045	61.5	15-1/2	394	6-7/8	175	7-1/2	190	36	17,22		
97R (H5/L2)	980061551	697RMF	600	95	740	37	9-9/16	242	6-7/8	175	7-1/2	190	36	17,22		
101	980061528	6101MF	650	110	800	36	10-1/4	260	7-1/16	179	6-11/16	170	36	22,E		
140R (H4/LN1)	980061525	5140RMF	445	76	545	28	8-1/4	210	6-7/8	175	7-1/2	190	36	17,22		
151R	980061526	5151RMF	340	55	410	22.5	7-3/4	197	5-1/8	129	8-7/8	226	36	17,22		
124	980061529	6124MF	700	100	860	37.5	10-1/4	260	6-7/8	175	8-3/8	212	36	22		
S46B24R (Prius)	980061553	9A51P	325	60	390	29.5	9-1/4	235	5	127	8-5/8	220	36	22,38,39,J		
46A24L (Miata)	980061714	8AMU1R	320	45	400	24	7-3/4	197	5-1/8	130	7-1/8	181	36	2,13,38,39		
GROUP NO.	ITEM NUMBER	PART NO.	20 HR CAP.	6 HR CAP.	MINS @ 75 A	WEIGHT (lbs)	LENGTH		WIDTH		HEIGHT		WARRANTY FREE MO.	FOOTNOTES		
							in	mm	in	mm	in	mm				
6-VOLT FLOOR SCRUBBER AND SWEEPER																
901	980061717	9C11	250	210	130	73	11-3/4	298	7	178	11-1/2	292	6	11,17,19,25,34,V		
902	980061715	8C6V	330	270	170	97.5	11-3/4	298	7	178	14-3/8	365	6	11,17,19,25,34,V		
903	980061716	8L16	370	295	190	111	11-3/4	298	7	178	16-3/8	411	6	11,17,19,25,34,W		
12-VOLT FLOOR SCRUBBER AND SWEEPER																
921	980061718	9C12	228	180	115	127	15-1/2	394	7	178	14-1/4	362	6	11,17,25,34,V		
GROUP NO.	ITEM NUMBER	PART NO.	20 HR CAP.	5 HR CAP.	MINS @ 75 A	WEIGHT (lbs)	LENGTH		WIDTH		HEIGHT		WARRANTY FREE MO.	FOOTNOTES		
							in	mm	in	mm	in	mm				
12-VOLT GOLF CAR																
GC12	980137415	GC12T	150	120	70	85	13	329	7-1/8	181	11	280	12	11,N		
GROUP NO.	ITEM NUMBER	PART NO.	CCA	REF. MCA	R.C.	MINS @ 25 A	20 HR CAP.	WEIGHT (lbs)	LENGTH		WIDTH		HEIGHT		WARRANTY FREE MO.	FOOTNOTES
									in	mm	in	mm	in	mm		
12-VOLT WHEELCHAIR AGM VALVE REGULATED																
U1	980061538	8AU1	200	240	45	54	32	23	7-3/4	197	5-1/8	130	7-1/4	184	12	2,38,39,Y
22NF	980061550	8A22NF	350	420	85	95	55	37	9	228	5-1/2	140	9-1/4	235	12	2,38,39,G
GROUP NO.	ITEM NUMBER	PART NO.	PERFORMANCE LEVEL			WEIGHT (lbs)	LENGTH		WIDTH		HEIGHT		WARRANTY FREE MO.	FOOTNOTES		
			CCA	10 HR CAP.			in	mm	in	mm	in	mm				
12 VOLT AGM & CONVENTIONAL POWER SPORTS																
—	980075886	ETX14L	220	12		11.5	5-7/8	150	3-7/16	88	5-3/4	145	6	13,38,39,M		
	980063654	ETX15L	220	13		11.5	5-1/4	134	3-1/2	90	6-9/16	166	6	13,38,39,M		
	980066061	ETX16	325	19		17.0	6-7/8	175	4	100	6-1/8	155	6	13,38,39,42,74,M		
	980075885	ETX18L	340	20		18.0	8-1/8	206	3-9/16	91	6-3/8	163	6	13,38,39,M		
	980101227	ET7A	90	6		5.5	5-7/8	150	3-7/16	87	3-3/4	95	6	13,38,39,ZZ		
	980101225	ETZ7S	130	6		5	4-7/16	113	2-3/4	70	4-3/16	107	6	13,38,39,ZZ		
	980101224	ETZ10S	190	8.6		6.9	5-15/16	151	3-7/16	87	3-5/8	92	6	13,38,39,ZZ		
	980101226	ETZ14S	230	11.2		9.4	5-15/16	151	3-7/16	87	4-5/16	110	6	13,38,39,ZZ		
	980115932	YTX7ABSFP	105	6		6.3	6	150	3-7/16	87	3-3/4	94	6	13,ZZ		
	980115933	YTX7LBSFP	100	6		6.1	4-1/2	114	2-13/16	71	5-3/16	131	6	13,ZZ		
	980115929	YT7BBSFP	120	6.5		5.9	6	150	2-9/17	65	3-11/16	93	6	13,ZZ		
	980115926	YT12ABSFP	175	10		7.7	6	150	3-7/16	87	4-3/16	105	6	13,ZZ		
	980115927	YT12BBSFP	210	10		9	6	150	2-3/4	69	5-1/8	130	6	13,ZZ		
	980115928	YT14BBSFP	210	12		11.8	6-1/8	150	2-3/4	70	5-3/4	145	6	13,ZZ		
	980115930	YB9BFP	-	9		5.3	5-5/16	135	3	75	5-1/2	139	6	12,ZZ		
	980115934	YB12AAFP	-	12		6.8	5-5/16	134	3-3/16	80	6-5/16	160	6	12,ZZ		
	980115925	YB12CAFP	-	12		7.1	5-5/16	134	3-9/16	80	6-7/8	175	6	12,ZZ		
	980115931	YB16ALA2FP	-	16		8.6	8-1/8	207	2-13/16	71.5	6-7/16	164	6	12,ZZ		



Footnotes

- 2 Black cover / Gray case
- 11 Low maintenance - low antimony grids
- 12 Hybrid construction
- 13 AGM Technology
- 17 Includes handle
- 19 Includes lifting ledges
- 22 Flush manifold vented cover
- 25 With individual vent caps
- 34 Ratings after 15 cycles
- 38 "Non-spillable" defined by DOT (Department of Transportation) definitions
- 39 "Non-spillable" defined by ICAO (International Civil Aviation Organization) and IATA (International Airline Transport Association) definitions
- 42 Height without adapter
- 74 Shipped with 20mm height adapter

Terminal Footnotes

- E Automotive Side Terminal
- G Offset post, horizontal hole, stainless steel 5/16" bolt and hex nut (T881)
- J Pencil Posts
- M Molded-in top and side connection terminal (ETX)
- N Vertical Stainless Steel 5/16 " - 18 studs (THPT)
- V Molded-in offset SAE post and vertical 5/16" POS. and NEG. stainless steel studs
- W Wide L terminal with 3/8" diameter hole (T882)
- Y Small L terminal with round hole
- ZZ JIS Power Sports

- Batteries are maintenance-free calcium grids, except where noted
- Batteries manufactured in black cases & covers, except where noted
- SAE or DIN auto posts used, unless noted
- Warranty is suggested months
- Weights are approximates
- CA and MCA are reference ratings, for comparison only
- Other than CCA and RC ratings are "nominal"
- CCA and RC ratings conform to B.C.I. specifications

PROPOSITION 65 WARNING: Battery posts, terminals and related accessories contain lead and lead compounds, chemicals known to the State of California to cause cancer and reproductive harm. Batteries also contain other chemicals known to the State of California to cause cancer. **WASH HANDS AFTER HANDLING.**